



Knauf Data Sheet

CI-DW-DS 02-14

# **Friendly Feel<sup>®</sup> Duct Wrap**

*with ECOSE<sup>®</sup> Technology*



- 
- For cooling, heating or dual temperature service.

- 
- Friendly Feel Duct Wrap—meets the most stringent IAQ tests—GREENGUARD GOLD and California's Section 01350 standard.

- 
- The white facing offers exceptional durability and performance for exposed applications.



**Facts at a glance**

- Fire-resistant facing
- Conforms to flat or irregular surfaces
- Excellent acoustical properties
- ECOSE Technology is a revolutionary binder based on rapidly renewable bio-based materials rather than non-renewable petroleum-based chemicals such as phenol, formaldehyde, acrylics or artificial colors.

# Friendly Feel<sup>®</sup> Duct Wrap with ECOSE<sup>®</sup> Technology

## Description

Knauf Insulation Friendly Feel<sup>®</sup> Duct Wrap with ECOSE<sup>®</sup> Technology is a thermal and acoustical insulation blanket made from highly resilient, inorganic glass mineral wool bonded by ECOSE Technology. It is available unfaced, with a foil-scrim-kraft (FSK) jacket and with a white metalized polypropylene-scrim-kraft (PSK) jacket. Vapor retarders provide a 2" (51 mm) staple flange on one edge, and the factory-applied facing assures uniform quality.

## ECOSE Technology

ECOSE Technology is a revolutionary binder chemistry that makes Knauf Insulation products even more sustainable than ever. It features rapidly renewable bio-based materials rather than non-renewable petroleum-based chemicals traditionally used in glass mineral wool insulation products. ECOSE Technology reduces binder embodied energy and does not contain phenol, formaldehyde, acrylics or artificial colors.

## Application

Knauf Insulation Friendly Feel Duct Wrap is used as external insulation on commercial or residential heating or air conditioning ducts. It is suitable for the exterior of rectangular or round sheet metal ducts and spaces or surfaces where temperature and condensation must be controlled.

## Features and Benefits

- Low "k" factor significantly reduces heat gain or loss when applied with proper compression
- Flexible
- Lightweight
- Excellent acoustical properties
- Tough and resilient
- Energy conservation, which lowers operating costs
- System efficiency increases; energy usage/costs decrease
- Conforms easily to flat or irregular surfaces
- Rolls allow for faster installation, lower labor costs
- Reduces sound transmission through the duct wall

- Assured condensation control when installed at proper thickness using FSK or PSK facings, proper installation and sealed joints, seams and penetrations.
- Resists damage in shipment and during and after installation
- Knauf Insulation achieved UL GREENGUARD Gold Certification and is UL Environment Validated to be formaldehyde free. Products are certified to UL GREENGUARD standards for low chemical emissions into indoor air during product usage. Knauf Insulation has achieved a UL Environment claim validation for minimum 50% post-consumer recycled glass content in our insulation products.

## Sustainability

- Carbon-negative, meaning Knauf Insulation products used for thermal insulating purposes recover the energy that it took to make them in just hours or a few days, depending on the application. Once installed, the product continues to save energy and reduce carbon generation as long as it is in place.
- Glass mineral wool insulation with ECOSE Technology contains three primary ingredients:
  - Sand, one of the world's most abundant and renewable resources
  - A minimum 50% recycled post-consumer glass content and UL Environment verification every 6 months
  - ECOSE Technology which reduces binder embodied energy by up to 70%

## Specification Compliance In U.S.:

- ASTM C 1139 - unfaced; Type I, Type II, Grade 1 - 0.75 lb/ft<sup>3</sup>  
Grade 2 - 1.0 lb/ft<sup>3</sup>  
Grade 3 - 1.5 lb/ft<sup>3</sup>
- ASTM C 553; Type I, II, III
- ASTM C 1136; Type II
- ASTM C 1290
- UL GREENGUARD Gold Certification and UL Environment Validated to be formaldehyde free.

- HHI-558C; Form B, Type I, Class 7
- NFPA 90A and 90B

## In Canada:

- CAN/ULC S102-M88
- CAN/CGSB-51.11-92

## Technical Data

### Surface Burning Characteristics

- UL/ULC Classified FHC 25/50 (FSK, Unfaced)
- California Title 24 (installed at 25% compression)
- Unfaced and FSK wrap have a Flame Spread 25 and Smoke Developed 50 when tested in accordance with UL 723, ASTM E 84, CAN/ULC S102-M88 and NFPA 255. PSK wrap has a Flame Spread 25 and Smoke Developed 50 when tested in accordance with ASTM E 84.

### Temperature Range (ASTM C 411)

- Faced, can be used on ducts operating up to 250°F (121°C)
- Unfaced, up to 350°F (177°C)

### Water Vapor Permeance (ASTM E 96, Procedure A)

- FSK and PSK facings have maximum water vapor permeance of .02 perms.

### Water Vapor Sorption (ASTM C 1104)

- Less than 5% by weight when tested for 96 hours at 120°F (49°C) and 95% relative humidity

### Corrosiveness (ASTM C 665)

- Does not accelerate corrosion on steel, copper or aluminum

### Corrosion (ASTM C 1617)

- The corrosion rate in mils/yr will not exceed that of the 1 ppm chloride solution.

### Mold Growth (ASTM C 1338)

- No growth

### Puncture Resistance (TAPPI Test T803) (Beach Units)

- FSK and PSK: 25

- Tested and certified to meet all the requirements of EUCEB.

**Insertion Loss (Reduction of Sound Transmitted Through Duct Wall)**  
 (Sound and Vibration Design and Analysis, National Environmental Balancing Bureau, 1994)

Duct Dimensions		Sheet Metal	Duct Wrap		Insertion Loss, dB/LF of Duct						
			Nominal Thickness	Nominal Density	63Hz	125Hz	250Hz	500Hz	1000Hz	2000Hz	4000Hz
12" x 12"	(305 mm x 305 mm)	24 GA	1½" (38 mm)	.75 PCF (12 kg/m <sup>3</sup> )	.6	.6	.6	.7	7.4	14.2	20.9
24" x 12"	(610 mm x 305 mm)	24 GA	1½" (38 mm)	.75 PCF (12 kg/m <sup>3</sup> )	.6	.6	.6	.7	7.4	14.2	20.9
48" x 12"	(1219 mm x 305 mm)	22 GA	1½" (38 mm)	.75 PCF (12 kg/m <sup>3</sup> )	.5	.5	.5	.6	7.4	14.1	20.9
24" x 24"	(610 mm x 610 mm)	22 GA	1½" (38 mm)	.75 PCF (12 kg/m <sup>3</sup> )	.5	.5	.5	.6	7.4	14.1	20.9
24" x 12"	(610 mm x 305 mm)	26 GA	1½" (38 mm)	.75 PCF (12 kg/m <sup>3</sup> )	.8	.8	.8	.8	7.5	14.2	21.0
24" x 8"	(610 mm x 203 mm)	26 GA	2" (51 mm)	.75 PCF (12 kg/m <sup>3</sup> )	1.0	1.0	1.0	3.6	10.4	17.1	23.9

**Condensation Control**

Recommended minimum install R-Values for condensation control on flat surfaces. Surface emittance : 0.2 (aged aluminum foil or galvanized sheet metal).

RH %	Operating Temperature														
	45°F (7°C) Ambient Temperature (°F)					55°F (13°C) Ambient Temperature (°F)					60°F (18°C) Ambient Temperature (°F)				
	70	80	90	100	110	70	80	90	100	110	70	80	90	100	110
60	2.2 <sup>1</sup>	3.3 <sup>1</sup>	4.3 <sup>2</sup>	4.3 <sup>2</sup>	5.4 <sup>3</sup>	1.1 <sup>1</sup>	2.2 <sup>1</sup>	3.3 <sup>1</sup>	3.3 <sup>1</sup>	4.3 <sup>2</sup>	1.1 <sup>1</sup>	1.1 <sup>1</sup>	2.2 <sup>1</sup>	3.3 <sup>1</sup>	4.3 <sup>2</sup>
70	3.3 <sup>1</sup>	5.4 <sup>3</sup>	6.5 <sup>4</sup>	7.6 <sup>5</sup>	—	1.1 <sup>1</sup>	3.3 <sup>1</sup>	4.3 <sup>2</sup>	6.5 <sup>4</sup>	6.5 <sup>4</sup>	1.1 <sup>1</sup>	1.1 <sup>1</sup>	3.3 <sup>1</sup>	5.4 <sup>3</sup>	6.5 <sup>4</sup>
80	7.0 <sup>4</sup>	—	—	—	—	3.3 <sup>1</sup>	6.5 <sup>4</sup>	—	—	—	2.2 <sup>1</sup>	3.3 <sup>1</sup>	6.5 <sup>4</sup>	—	—
90	—	—	—	—	—	—	—	—	—	—	6.5 <sup>4</sup>	—	—	—	—

<sup>1</sup> All Duct Wrap products

<sup>2</sup> 0.75 PCF, 2" and greater; 1.0 PCF, 1½" and greater; 1.5 PCF, 1½" and greater

<sup>3</sup> 0.75 PCF, 2" and greater; 1.0 PCF, 2"; 1.5 PCF, 2"

<sup>4</sup> 0.75 PCF, 2½" and greater

**Thermal Efficiency (ASTM C 177)**

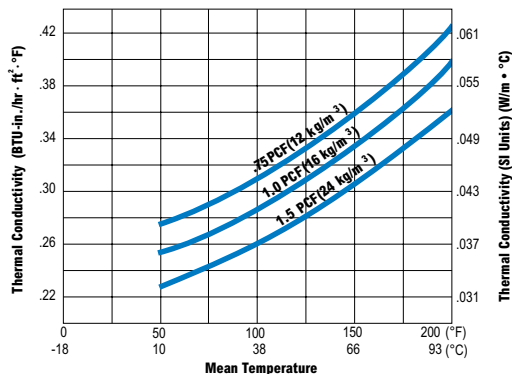

Mean Temperature	0.75 PCF		1.0 PCF		1.5 PCF	
	k	k (SI)	k	k (SI)	k	k (SI)
50°F (10°C)	.28	.040	.26	.037	.23	.033
75°F (24°C)	.29	.042	.27	.039	.24	.035
100°F (38°C)	.31	.045	.29	.042	.26	.037
125°F (52°C)	.33	.048	.31	.045	.28	.040
150°F (66°C)	.36	.052	.34	.049	.31	.042
175°F (80°C)	.39	.056	.37	.053	.33	.048
200°F (93°C)	.43	.063	.40	.058	.36	.052

## Application

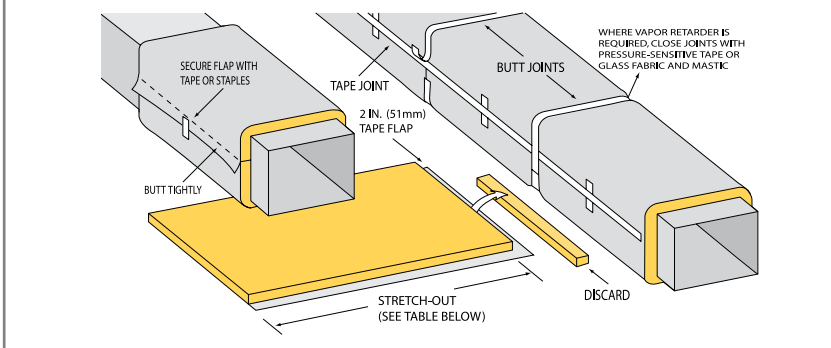

## Stretch-Outs

Labeled Thickness	Installed Compressed Thickness	Round	Square	Rectangular
1½" (38 mm)	1⅛" (29 mm)	P+9½" (241 mm)	P+8" (203 mm)	P+7" (178 mm)
2" (51 mm)	1½" (38 mm)	P+12" (305 mm)	P+10" (254 mm)	P+8" (203 mm)
2⅜" (56 mm)	1⅝" (42 mm)	P+13" (330 mm)	P+11" (279 mm)	P+8½" (216 mm)
2½" (64 mm)	1⅞" (48 mm)	P+14½" (368 mm)	P+12½" (318 mm)	P+9½" (241 mm)
3" (76 mm)	2¼" (57 mm)	P+17" (432 mm)	P+14½" (368 mm)	P+11½" (292 mm)

P = Perimeter of duct to be installed.

## Forms Available/R-Values@75°F Mean Temperature

Density	Thickness	Width	Length	Facing	Out-Of Package R-Value	Installed R-Value
.75 PCF (12 kg/m³)	1½" (38 mm)	48" (1219 mm)	100' (30.48 m)	FSK, PSK, unfaced	5.1	4.2
	2" (51 mm)		75' (22.86 m)		6.8	5.6
	2⅜" (56 mm)		75' (22.86 m)		7.4	6.0
	2½" (64 mm)		75' (22.86 m)		8.5	7.0
1.0 PCF (16 kg/m³)	3" (76 mm)	50' (15.24 m)	10.2		8.4	
	1½" (38 mm)	48"	100' (30.48 m)		5.6	4.5
1.5 PCF (24 kg/m³)	2" (51 mm)	(1219 mm)	75' (22.86 m)		7.4	6.0
	1½" (38 mm)	48"	75' (22.86 m)		6.1	4.8
	2" (51 mm)	(1219 mm)	50' (15.24 m)	8.2	6.4	

## Application & Specification Guidelines

### Storage

- Protect stored insulation from water damage, construction damage and other abuse.
- If stored outside, proper protection from weather conditions should be provided.

### Preparation

- Install Knauf Insulation Friendly Feel Duct Wrap over clean, dry sheet metal ducts.
- All sheet metal joints and seams must be sealed to prevent air leakage from the duct.

### Application

- Install Knauf Insulation Friendly Feel Duct Wrap with facing to the outside to obtain specified R-value using a maximum of 25% compression.
- Butt all insulation joints firmly together. Longitudinal seam of the vapor retarder must be overlapped a minimum of 2" (51 mm). A 2" (51 mm) tab is provided for the circumferential seam and must be overlapped.
- Where vapor retarder performance is necessary, all penetrations, joints, seams and damage to the facing should be sealed with an FSK, PSK or foil tape or glass fabric and mastic prior to system startup.
- Pressure sensitive tapes should be a minimum 3" (76 mm) wide and be applied with moving pressure using an appropriate sealing tool. Staples should be outward clinch and placed approximately 6" (152 mm) on center.
- Closure systems should have a 25/50 F.H.C. per UL 723.
- For rectangular ducts over 24" (610 mm) wide, secure the insulation to the bottom side of the duct with mechanical fasteners spaced on 18" (457 mm) centers to reduce sag. Care should be taken to avoid overcompressing the insulation with the retaining washer.

For more information call (800) 825-4434, ext. 8485

or visit us online at [www.knaufinsulation.us](http://www.knaufinsulation.us)



Knauf Insulation GmbH  
One Knauf Drive  
Shelbyville, IN 46176

Sales and Marketing (800) 825-4434, ext. 8485

Technical Support (800) 825-4434, ext. 8512

Fax (317) 398-3675

Information [info.us@knaufinsulation.com](mailto:info.us@knaufinsulation.com)

World Wide Web [www.knaufinsulation.us](http://www.knaufinsulation.us)

©2014 Knauf Insulation GmbH.

- It is neither necessary nor desirable to adhere duct wrap to duct surfaces with adhesive.
- Unfaced Duct Wrap should be overlapped with a minimum of 2" (51 mm) and fastened with 4" (102 mm) to 6" (152 mm) nails or skewers placed 4" (102 mm) apart, or secured with a wire or banding system. Care must be taken to avoid damaging the duct wrap. Refer to diagram for staple stitching and butt-joint method.

#### Installation Procedures

- Use the table (right inside fold) to determine stretch-outs required for the nominal thickness of insulation to limit average compression of the insulation 25% or less.

#### Glass Mineral Wool and Mold

Glass wool insulation will not sustain mold growth. However, mold can grow on almost any material when it becomes wet and contaminated. Carefully inspect any insulation that has been exposed to water. If it shows any sign of mold, it must be discarded. If the material is wet but shows no evidence of mold, it should be dried rapidly and thoroughly. If it shows signs of facing degradation from wetting, it should be replaced. Air handling insulation used in the air stream must be discarded if exposed to water.

#### Notes

The chemical and physical properties of Knauf Insulation Friendly Feel Duct Wrap represent typical average values determined in accordance with accepted test methods. The data is subject to normal manufacturing and testing variations. The data is supplied as a technical service and is subject to change without notice. References to numerical flame spread ratings are not intended to reflect hazards presented by these or any other materials under actual fire conditions.

Check with your Knauf Insulation sales representative to assure information is current.



#### LEED Eligible Product

Use of this product may help building projects meet green building standards as set by the Leadership in Energy and Environmental Design (LEED) Green Building Rating System.

LEED V 4 - Credit MR 3 - Regional Materials

LEED V 4 - Credit MR 4 - Recycled Content



This product has been tested and is certified to meet the EUCEB requirements.



#### UL GREENGUARD Gold<sup>SM</sup>

Knauf Insulation building insulation achieved UL GREENGUARD Gold Certification and are UL Environment Validated to be formaldehyde free.



#### UL GREENGUARD Certification Program<sup>SM</sup>

Products are certified to UL GREENGUARD standards for low chemical emissions into indoor air during product usage. For more information, visit [ul.com/gg](http://ul.com/gg).



Knauf Insulation has achieved a UL Environment claim validation for minimum 50% post-consumer recycled glass content in our insulation products.